

VÁLIDA HASTA EL 31 DE DICIEMBRE 2024



www.gerardi.it

10 - 14 / 09 / 2024
Pab. 3 - Stand 3b62

9 - 12 / 10 / 2024
Pab. 11 - Stand D18

OFERTA ESPECIAL

PUNTO CERO

La primera etapa
hacia la automatización.



NEW
2024

NEW 2024! SOLICITA MÁS INFORMACIÓN

MESAS MAGNÉTICAS

¡Perfectas para operaciones de fresado y más!

- Eliminación completa de vibraciones durante el mecanizado
- Mejora el acabado y reduce el desgaste de la herramienta
- Resistencia al estrés y la deformación y posicionamiento preciso de la pieza de trabajo



Descarga el catálogo

Mordazas COMPACT GRIP

Mordazas autocentrantes con bocas reversibles - Perfectas para centros de mecanizado de 5 ejes

Art.650

Escanea el código QR y descubre más información



Equipo estándar: 1 llave inglesa Art.375, 1 tope de trabajo Art.370EM, 1 par de tuercas autocentrantes Art.297, 2 tuercas de posicionamiento Art.650G ranura en T de 16 mm, 1 placa de bloqueo de deslizamiento Art.650F

+ Tope de trabajo magnético Art. 370EM

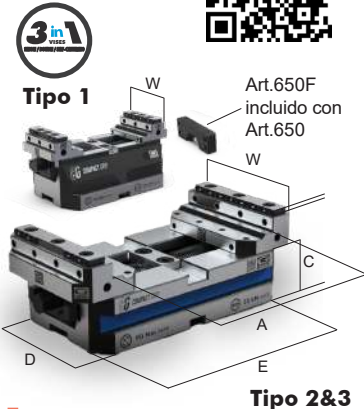

Tipo	Anchura Boca W	Apertura Max. A	Altura Mordaza B	Altura Base C	Anchura Base D	Anchura Base E	Kg	Ref.	€	PRECIO ESPECIAL €
1 12kN	50	54	65	45	79,9	80	1,9	7.65.01080	777	649
		94				120	2,7	7.65.01120	897	749
		134				160	3,4	7.65.01160	1.015	849
2 22kN	88	96	65	38	89,9	120	3,6	7.65.02120	955	749
		136				160	4,4	7.65.02160	1.075	849
		176				200	5,2	7.65.02200	1.194	949
		216				240	5,8	7.65.02240	1.314	1.049
		133				160	9,1	7.65.03160	1.552	1.149
3 32kN	123	183	89	57	124,9	210	10,9	7.65.03210	1.790	1.249
		233				260	12,8	7.65.03260	2.029	1.349
		283				310	14,8	7.65.03310	2.387	1.649
		333				360	17	7.65.03360	2.625	1.849

MAXIGRIP

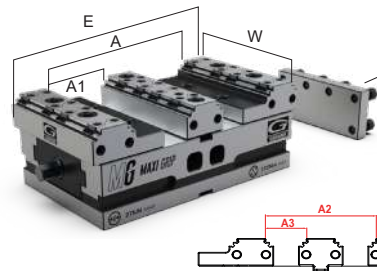

Art.685

Mordaza MaxiGrip - Sujeción 3 en 1 - Autocentrado, Simple y Doble

Tipo	kN	A	A1	A2	A3	W	E	Kg	Ref.	PRECIO €	PRECIO ESPECIAL €
4x270	41	200	83	104	35	158	270	28,5	76854270	2.920	2.299
4x420		344	155	248	107	420	40	76854420	3.870	3.099	

Art.684

Mordaza MaxiGrip - Sólo Autocentrado

Tipo	kN	A	A1	A2	A3	W	E	Kg	Ref.	PRECIO €	PRECIO ESPECIAL €
4x270	41	200	-	104	-	158	270	25	76844270	2.500	1.999
4x420		344	-	248	-	420	36	76844420	3.450	2.799	

ELEVADORES PARA MORDAZAS COMPACT GRIP

Art.651H

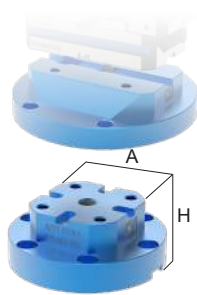

Tipo	Min A	H=50			H=75			H=100		
		Ref.	PRECIO €	PRECIO ESPECIAL €	Ref.	PRECIO €	PRECIO ESPECIAL €	Ref.	PRECIO €	PRECIO ESPECIAL €
1	80	7.65.1H1080/050	414	350	7.65.1H1080/075	425	350	7.65.1H1080/100	437	350
	120	7.65.1H1120/050	492	400	7.65.1H1120/075	517	400	7.65.1H1120/100	539	400
	160	7.65.1H1160/050	588	450	7.65.1H1160/075	620	500	7.65.1H1160/100	654	500
2	120	7.65.1H2120/050	588	450	7.65.1H2120/075	620	500	7.65.1H2120/100	654	500
	160	7.65.1H2160/050	588	500	7.65.1H2160/075	620	550	7.65.1H2160/100	654	550
	200	7.65.1H2200/050	588	550	7.65.1H2200/075	620	600	7.65.1H2200/100	654	600
	240	7.65.1H2240/050	727	600	7.65.1H2240/075	773	600	7.65.1H2240/100	820	650
3	160	7.65.1H3160/050	680	650	7.65.1H3160/075	726	650	7.65.1H3160/100	769	650
	210	7.65.1H3210/050	680	650	7.65.1H3210/075	726	700	7.65.1H3210/100	769	700
	260	7.65.1H3260/050	1.047	950	7.65.1H3260/075	1.106	950	7.65.1H3260/100	1.167	950
	310	7.65.1H3310/050	1.085	1.000	7.65.1H3310/075	1.146	1.000	7.65.1H3310/100	1.207	1.000
	360	7.65.1H3360/050	1.255	1.100	7.65.1H3360/075	1.326	1.100	7.65.1H3360/100	1.398	1.100

SOPORTE PIRAMIDAL PARA CENTROS DE 5 EJES - INCLUYE MORDAZAS MONTADAS Y ALINEADAS

Art.643H



Soposte piramidal de aluminio que permite el montaje simultáneo de 3 mordazas CompactGrip (con o sin mesas de cambio rápido) inclinadas a 45° o 60°, aumentando así el espacio de trabajo y permitiendo el mecanizado simultáneo de múltiples piezas incluso en puntos de difícil acceso.

Equipamiento estándar: 12 mordazas de sujeción Art.298 CGR, 1 cáncamo, 1 pasador de centrado, par de llaves Art.297.

+ MONTAJE Y ALINEAMIENTO INCLUIDO

KIT 1

Art. 643H + N°3 Art.650 T.1x120



Ref.	PRECIO €	PRECIO ESPECIAL €
6501120-G11-643H1-60	4.373	3.400

KIT 2

Art. 643H + N°3 Art.650 T.2x200

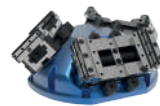

* Verificar el giro del husillo de la máquina

Ref.	PRECIO €	PRECIO ESPECIAL €
6502200-G11-643H2-30/45	5.571	4.200

KIT 3

Art. 643H + N°3 Art.650 T.3x210



* Verificar el giro del husillo de la máquina

Ref.	PRECIO €	PRECIO ESPECIAL €
6503210-G11-643H3-45	7.525	5.300



MESAS de cambio rápido

Mesas de cambio rápido para mordazas compactgrip - Perfectas para máquinas de 5 ejes

Art.660

Mesa rectangular de cambio rápido mecánico



Escanea el código QR
y descubre más
información

Equipamiento estándar: 4 Pernos Art.660B

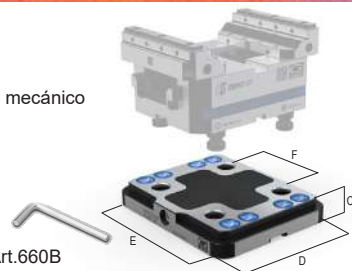

Tipo	C	D	E	Kg	Ref.	PRECIO €	PRECIO ESPECIAL €
1-2 (F=52)	27	116	150	3	9.66.05200	787	599
3 (F=96)	27	156	190	5,2	9.66.09600	1.133	899

Art.661

Mesa redonda de cambio rápido mecánico

Equipamiento estándar: 4 Pernos Art.660B

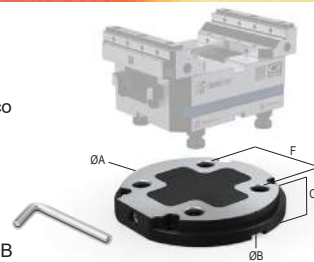

Tipo	ØA	ØB	C	Kg	Ref.	PRECIO €	PRECIO ESPECIAL €
1-2 (F=52)	156	120	27	3	9.66.15200	754	599
3 (F=96)	196	175	27	5,2	9.66.19600	1.102	899

Art.660S

Mesa rectangular libre de cambio rápido mecánico rígido con orificios mecanizables

Personalización no incluida

Equipamiento estándar: 4 Pernos Art.660B

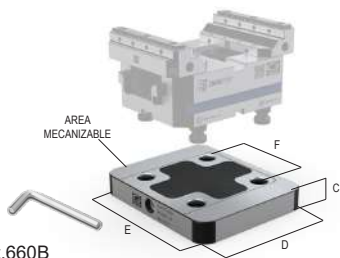

Tipo	C	D	E	Kg	Ref.	PRECIO €	PRECIO ESPECIAL €
1-2 (F=52)	27	126	150	3	9.66.0S520	638	499
3 (F=96)	27	156	190	5,2	9.66.0S960	870	699

Art.661S

TAMBIÉN CON PASO DE BARRA

Mesa redonda libre de cambio rápido mecánico endurecido con orificios mecanizables

Mesas de cambio rápido disponibles para cualquier tipo de mesas rotativas o de 4 ejes
Personalización no incluida

Equipamiento estándar: 4 Pernos Art.660B

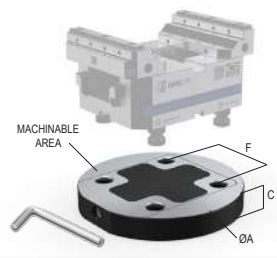

Tipo	ØA	C	Kg	Ref.	PRECIO €	PRECIO ESPECIAL €
1-2 (F=52)	156	27	3,8	9.66.1S5200	696	499
3 (F=96)	196	27	6	9.66.1S9600	1.159	699
	250	24	10	9.66.1S960-250	1.647	1.500
	300	24	15	9.66.1S960-300	1.750	1.600

Art.660R

Mesa reductora rectangular de cambio rápido mecánico

Equipamiento estándar: 4 Pernos Art.660B

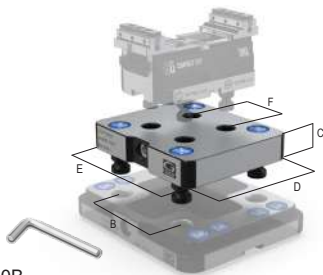

Tipo	B	C	D	E	Kg	Ref.	PRECIO €	PRECIO ESPECIAL €
F = 52	96	27	126	150	3,75	9.66.0R210	696	499

Art.661R

Mesa de reducción redonda

Equipamiento estándar: 4 Pernos Art.660B



Tipo	A	B	C	Kg	Ref.	PRECIO €	PRECIO ESPECIAL €
F = 52	158	96	27	3,75	9.66.1R210	870	499

Art.660B

Pernos de tracción de la mesa de cambio rápido



Tipo	Ref.	PRECIO /UD. €
1 - 2	9.66.0B100	31
3	9.66.0B200	33

Art.661H

Base elevadora de aluminio para mesa de cambio rápido, puede montarse con soportes o mediante Punto Cero



Art.661S

TAMBIÉN CON PASO DE BARRA

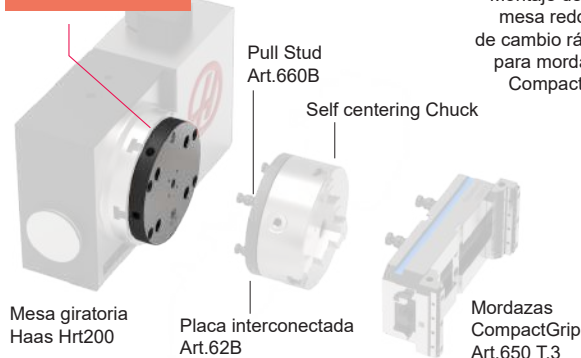

EJEMPLO
Montaje de una mesa redonda de cambio rápido para mordazas CompactGrip

Mordazas CompactGrip Art.650 T.3

Mordazas STANDARD FLEX

Innovador sistema de peine para el cambio rápido de placas de mordazas - Perfectas para centros de mecanizado verticales

Art.1A



Equipamiento estándar: 1 tope, 2 tuercas de posicionamiento para ranura de 16 mm, 2 placas Art. 291, 1 llave inglesa, 1 llave en "T"

+ 4 Pinzas de sujeción Art.298

Mordaza modular de precisión
Serie StardarFLEX



Escanea el código QR
y descubre más
información

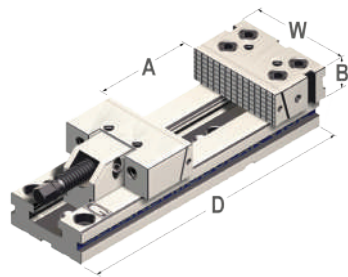

Tipo	Apertura max. A	Anchura Boca W	Altura Boca B	Longitud Base D	Ref.	PRECIO €	PRECIO ESPECIAL €
2 25kN	150	121 mm	38	345	1.1A.20000	925	789
	200			420	1.1A.32000	1.112	839
3 30kN	300	146 mm	48	520	1.1A.33000	1.283	949
	200			455	1.1A.42000	1.414	1.189
4 30kN	300	171 mm	58	555	1.1A.43000	1.555	1.239
	400			655	1.1A.44000	1.696	1.339
5 40kN	200			495	1.1A.52000	1.846	1.489
	300	196 mm	63	595	1.1A.53000	2.210	1.789
	400			695	1.1A.54000	2.582	2.039

DESCUENTO HASTA EL 20% * Comprando una mordaza completa



Mordazas EXTRA LARGAS

Mordazas con base extra grande, mucho más larga que las mordazas estándar - Perfectas para centros de mecanizado verticales

Art.21

(Sujeción Simple)

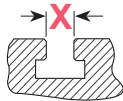

Equipamiento estándar: 1 tope de trabajo, 2 tuercas de posicionamiento para ranura de 16 mm, 2 placas Art. 291, 1 llave de tubo, 1 llave en "T"

+ 6 Pinzas de sujeción Art. 298

Mordaza modular XL
con dotación estándar

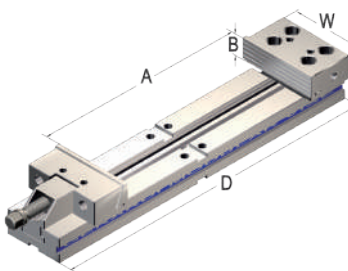

Tipo	Max opening A	Jaw width W	Jaw Height B	Base Length D	Kg	Ref.	PRECIO €	PRECIO ESPECIAL €
2 25kN	320	125 mm	40	520	17	2.21.23200	1.147	800
	360			580	32	2.21.33600	1.425	1.000
3 30kN	460	150 mm	50	680	35	2.21.34600	1.578	1.150
	500			766	52	2.21.45000	1.828	1.350
4 30kN	600	175 mm	60	866	56	2.21.46000	1.990	1.450
	700			966	61	2.21.47000	2.159	1.550

REDUCTION UP TO 20% * When bought with a complete vise

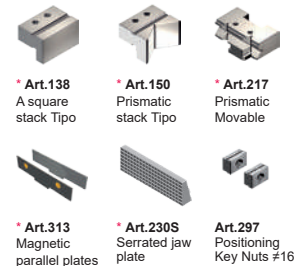

PLACAS MAGNÉTICAS paralelas

Amplia gama de alturas disponible en la página 4.27 - Lista general de precios w17

DESCUENTO HASTA EL 40%

PARA MORDAZAS STANDARD & STANDARD FLEX ART.1 e ART.1A

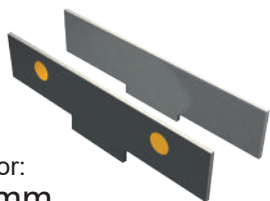

Grosor:
2,8mm

Art.414

También disponibles
placas magnéticas
paralelas universales

Tipo	Par de placas magnéticas paralelas	PRECIO /UD. €
1		73
2		93
3		116
4		136
5		155
6		176

Art.310

Precio por unidad en caso de compra conjunta	6 pares de barras paralelas (Art.313-313R)	PRECIO / UD. €	PRECIO KIT €
		50	300
		65	390
		75	450
		90	540
		100	600
		120	720

Art.311

Precio por unidad en caso de compra conjunta	10 pares de barras paralelas (Art.313-313R)	PRECIO / UD. €	PRECIO KIT €
		-	-
		-	-
		70	700
		80	800
		90	900
		100	1.000



Kits AUTOMÁTICOS

Unidad con control neumático y cilindro de efecto simple - Perfecto para centros de mecanizado verticales

PARA MORDAZAS STANDARD & STANDARDFLEX ART.1 e ART.1A

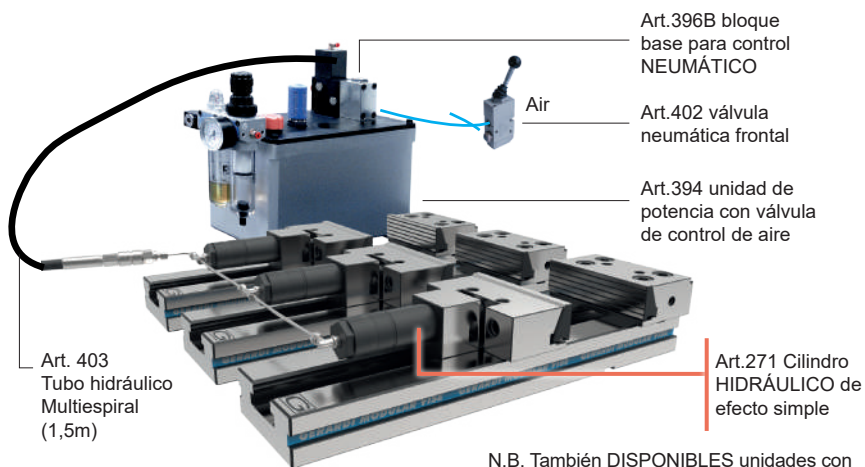

N.B. También DISPONIBLES unidades con electroválvulas electromagnéticas PARA CNC

MORDAZA NO INCLUIDA

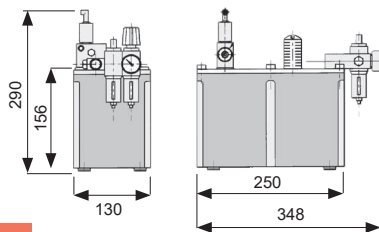

Nº1 CLAMPING

Art.392

Tipo	Trazo Art.271	Ref.	PRECIO €	PRECIO ESPECIAL €
2	26	4.39.22000	1.872	1.499
3		4.39.23000	1.884	1.499
4	40	4.39.24000	1.917	1.499
5		4.39.25000	2.109	1.599

KIT DE SUJECCIÓN SIMULTÁNEA DE MORDAZAS

*Art.405H Tubo de acero galvanizado adecuado (No incluido) Ø6 (m1,0) Ref.: 4.40.5H000

Art.392/2

(Art.271- 394 - 402 - 403)
Nº2 SUJECCIÓN SIMULTÁNEA
Art.392 + Nº1 Art.271

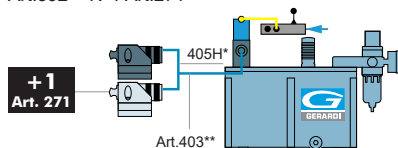

Tipo	Ref.	PRECIO €	PRECIO ESPECIAL €
2	4.39.22002	2.255	1.799
3	4.39.23002	2.277	1.799
4	4.39.24002	2.345	1.799
5	4.39.25002	2.725	2.099

Art.392/3

Nº3 SUJECCIÓN SIMULTÁNEA
Art.392 + Nº2 Art.271

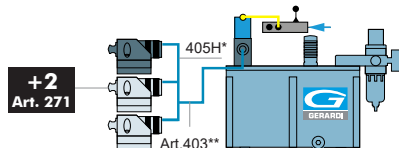

Tipo	Ref.	PRECIO €	PRECIO ESPECIAL €
2	4.39.22003	2.634	2.099
3	4.39.23003	2.667	2.099
4	4.39.24003	2.767	2.099
5	4.39.25003	3.341	2.499

Art.392/4

Nº4 SUJECCIÓN SIMULTÁNEA
Art.392 + Nº3 Art.271

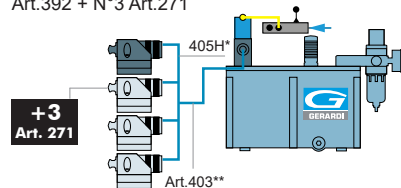

Tipo	Ref.	PRECIO €	PRECIO ESPECIAL €
2	4.39.22004	3.017	2.399
3	4.39.23004	3.059	2.399
4	4.39.24004	3.196	2.399
5	4.39.25004	3.958	2.999

KIT DE GRUPOS DE SUJECCIÓN INDEPENDIENTES

*Art.403 (Incluido) Tubo hidráulico Multiespiral 760bar completo de conexión rápida Art. 270A (m 1,5) Ref.: 4.40.30000

Art.392A/2

(Art.271- 394 - 402 - 403)
Nº2 SUJECCIÓN SIMULTÁNEA
Art.392 + Nº1 Art.407B

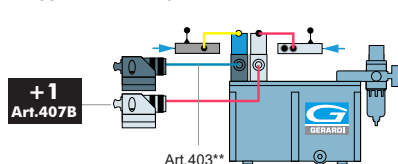

Tipo	Ref.	PRECIO €	PRECIO ESPECIAL €
2	4.39.2A202	3.063	2.399
3	4.39.2A302	3.083	2.399
4	4.39.2A402	3.161	2.399
5	4.39.2A502	3.639	2.799

Art.392A/3

Nº3 SUJECCIÓN SIMULTÁNEA
Art.392 + Nº2 Art.407B

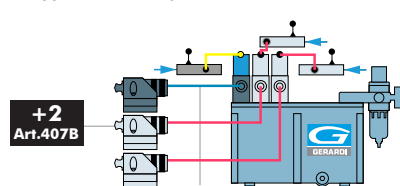

Tipo	Ref.	PRECIO €	PRECIO ESPECIAL €
2	4.39.2A203	3.564	2.799
3	4.39.2A303	3.596	2.799
4	4.39.2A403	3.695	2.799
5	4.39.2A503	4.247	3.299

Art.392A/4

Nº4 SUJECCIÓN SIMULTÁNEA
Art.392 + Nº3 Art.407B

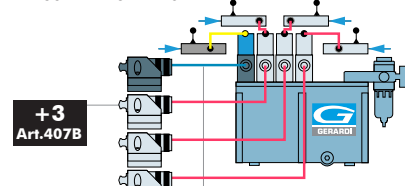

Tipo	Ref.	PRECIO €	PRECIO ESPECIAL €
2	4.39.2A204	4.413	3.599
3	4.39.2A304	4.455	3.599
4	4.39.2A404	4.584	3.599
5	4.39.2A504	5.319	4.199

Mordazas FMS

Para sujeción simple, doble y autocentrante - Perfectas para máquinas verticales y horizontales

Art.855

Base del cuerpo 3 en 1

Art.855A

Base del cuerpo
Solo autocentrante

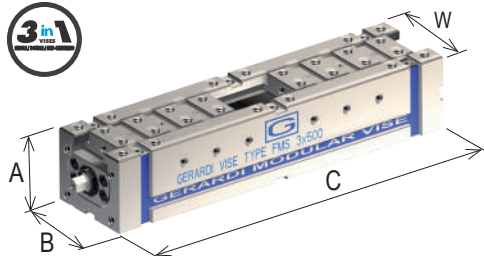

Tipo W	Altura Base A	Anchura Base B	Longitud Base C	Ref.	PRECIO €	Ref.	PRECIO €
2 (94mm) 25kN	90	95	400	5.85.52400	1.365	5.85.5240A	1.447
			500	5.85.52500	1.848	5.85.5250A	1.947
			600	5.85.52600	2.041	5.85.5260A	2.114
3 (124mm) 30kN	100	125	500	5.85.53500	1.773	5.85.5350A	1.864
			600	5.85.53600	2.452	5.85.5360A	2.559
4 (144mm) 30kN	120	145	600	5.85.54600	2.258	5.85.5460A	2.337

COMPON TU MORDAZA CON LOS CIENTOS DE MODELOS DISPONIBLES

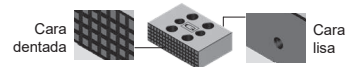

CONFIGURACIÓN DE DOBLE SUJECCIÓN

Art.860

Mordazas dobles con boca dentada

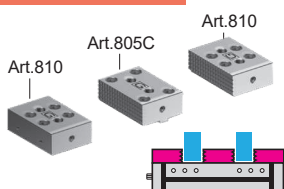

Tipo	Ref.	PRECIO €	PRECIO ESPECIAL €
2	5.86.02400	1.794	1.400
	5.86.02500	2.281	1.800
	5.86.02600	2.471	1.950
3	5.86.03500	2.264	1.800
	5.86.03600	2.941	2.300
4	5.86.04600	2.908	2.300

Art.863

Mordaza doble con paso

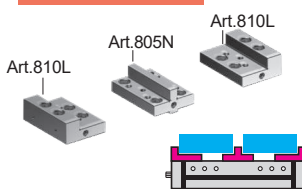

Tipo	Ref.	PRECIO €	PRECIO ESPECIAL €
2	5.86.32400	1.952	1.550
	5.86.32500	2.436	1.900
	5.86.32600	2.628	2.100
3	5.86.33500	2.420	1.900
	5.86.33600	3.098	2.450
4	5.86.34600	3.104	2.450

Art.865

Doble mordaza con bocas abatibles de cambio rápido (sistema de peine)

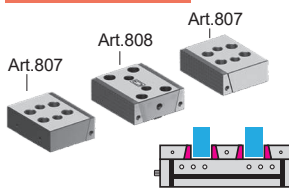

Tipo	Ref.	PRECIO €	PRECIO ESPECIAL €
2	5.86.52400	2.120	1.700
	5.86.52500	2.604	2.100
	5.86.52600	2.798	2.200
3	5.86.53500	2.735	2.200
	5.86.53600	3.418	2.700
4	5.86.54600	3.540	2.800

Art.866

Mordaza doble con paso flotante (3x5)

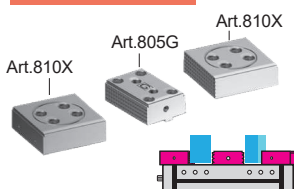

Tipo	Ref.	PRECIO €	PRECIO ESPECIAL €
2	5.86.62400	2.242	1.800
	5.86.62500	2.728	2.200
	5.86.62600	2.918	2.300
3	5.86.63500	2.761	2.200
	5.86.63600	3.439	2.700
4	5.86.64600	3.391	2.700

Art.867

Mordaza doble con paso flotante con placas ajustables

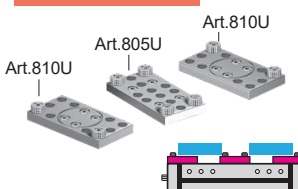

Tipo	Ref.	PRECIO €	PRECIO ESPECIAL €
2	5.86.72400	2.618	1.999
	5.86.72500	3.048	2.328
	5.86.72600	3.293	2.516
3	5.86.73500	3.171	2.423
	5.86.73600	3.850	2.941
4	5.86.74600	3.874	2.960

* SÓLO CONFIGURACIÓN AUTOCENTRANTE

* SÓLO para configuración autocentrante, el separador Art.850T incluido en el precio

Art.855A

Art.810

Cuerpo Base -
Sólo Autocentrante

2 Mordazas dentadas

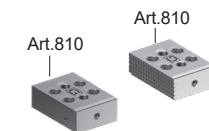
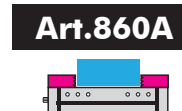

Tipo	* PRECIO €
2	1.647
	2.135
	2.325
	2.100
3	2.776
	2.682

Art.855A

Art.810L

Cuerpo Base -
Sólo Autocentrante

2 Mordazas con paso

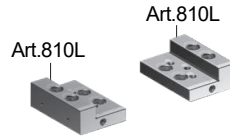
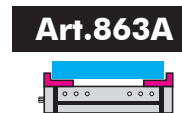

Tipo	* PRECIO €
2	1.722
	2.206
	2.398
	2.172
3	2.848
	2.775

Art.855A

Art.807

Cuerpo Base -
Sólo Autocentrante

2 Mordazas abatibles de cambio rápido

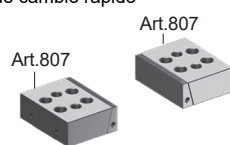
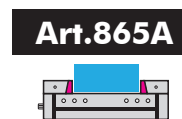

Tipo	* PRECIO €
2	1.846
	2.330
	2.524
	2.332
3	3.015
	3.008

Art.855A

Art.814 (nº2)

Art.805V (nº2)

Cambio rápido mordazas abatibles

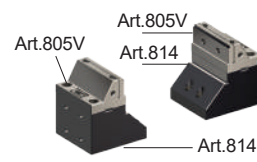
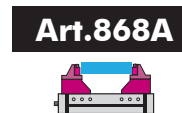

Tipo	* PRECIO €
2	2.113
	2.578
	2.757
	2.590
3	3.246
	3.328

Art.855A

Art.810J

Cambio rápido mordazas abatibles

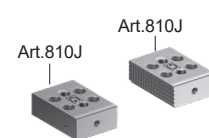
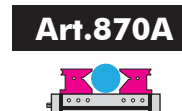

Tipo	* PRECIO €
2	1.882
	2.367
	2.558
	2.377
3	3.054
	3.108

Mordazas MULTIFLEX

Para sujeción múltiple de 1 a 19 piezas de distintos tamaños - Ideal para máquinas verticales y horizontales



Equipamiento de serie : 1 llave en «T», 2 llaves de posicionamiento y 4 topes. Cada mordaza se suministra para la sujeción de 4 piezas.

+ 6 pinzas de sujeción Art.298

(* Tipos suministrados para la sujeción de 3 piezas)

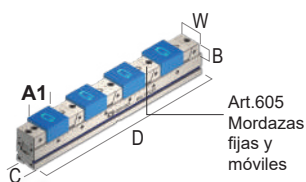

Art.605
Mordazas
fijas y
móviles

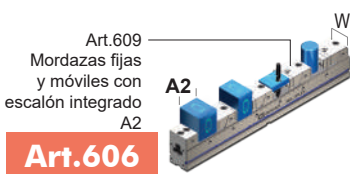

Art.609
Mordazas fijas
y móviles con
escalón integrado
A2

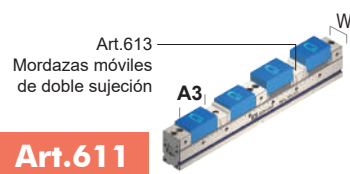

Art.613
Mordazas móviles
de doble sujeción

Art.600

Art.600W

Art.606

Art.611

Tipo	B	C	D	W	A1 mm	Ref.	PRECIO €	PRECIO ESPECIAL €	A2 mm	Ref.	PRECIO €	PRECIO ESPECIAL €	A3 mm	Ref.	PRECIO €	PRECIO ESPECIAL €
1 20kN	32/25	50	49		4x8	6.60.01300	1.204	749	* 3x19	6.60.61300	1.822	1.200	* 3x21	6.61.11300	1.822	1.200
					4x33	6.60.01400	1.308	849	4x23	6.60.61400	1.898	1.300	4x46	6.61.11400	1.898	1.300
					4x58	6.60.01500	1.425	949	4x48	6.60.61500	2.013	1.400	4x71	6.61.11500	2.013	1.400
					4x83	6.60.01600	1.553	1.049	4x73	6.60.61600	2.141	1.500	4x96	6.61.11600	2.141	1.500
					4x108	6.60.01700	1.736	1.149	4x97	6.60.61700	2.327	1.600	4x121	6.61.11700	2.327	1.600
2 30kN	40	75	74		4x12	6.60.02400	1.566	1.099	* 3x28	6.60.62400	2.266	1.550	4x34	6.61.12400	2.266	1.550
					4x37	6.60.02500	1.681	1.249	4x24	6.60.62500	2.386	1.650	4x59	6.61.12500	2.386	1.650
					4x62	6.60.02600	1.811	1.349	4x49	6.60.62600	2.517	1.750	4x84	6.61.12600	2.517	1.750
					4x87	6.60.02700	1.940	1.449	4x74	6.60.62700	2.647	1.850	4x109	6.61.12700	2.647	1.850
					4x112	6.60.02800	2.114	1.549	4x99	6.60.62800	2.832	1.950	4x134	6.61.12800	2.832	1.950
3 40kN	60	100	99		4x137	6.60.02900	2.302	1.749	4x124	6.60.62900	3.021	2.050	4x158,5	6.61.12900	3.021	2.050
					4x59	6.60.03700	2.244	1.649	4x44	6.60.63700	3.057	2.150	4x77	6.61.13700	3.057	2.150
					4x84	6.60.03800	2.428	1.749	4x69	6.60.63800	3.245	2.250	4x102	6.61.13800	3.245	2.250
					4x109	6.60.03900	2.619	1.949	4x94	6.60.63900	3.431	2.450	4x127	6.61.13900	3.431	2.450
					4x134	6.60.03100	2.869	2.149	4x119	6.60.63100	3.682	2.650	4x152	6.61.13100	3.682	2.650

PARA PLACAS PARALELAS MAGNÉTICAS Y PLACAS DE MORDAZAS PARALELAS



Art.616
Par de placas
magnéticas paralelas
para Art. 600

DESCUENTO HASTA EL
20%

Comprando una mordaza completa



Art.610E
Placa de mordazas
paralelas para
Art.606

DESCUENTO HASTA EL
20%

Comprando una mordaza completa

Mordazas MULTITASKING

Mordazas autocentrantes y excéntricas - Perfectas para centros de mecanizado de 5 ejes

! Posibilidad de solicitar 2 mordazas Art.645T en lugar de Art.645E

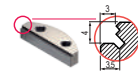

Equipo estándar : 1 tope, 1 llave hexagonal, par de tuercas de posicionamiento Art.297, 1 pasador recto Art.640P

Art.640	1	2	3x166	3x266
Tipo	1	2	3x166	3x266
Ref.	6.64.01000	6.64.02000	7.64.03166	7.64.03266
PRECIO €	1.858	2.285	2.658	2.785
PRECIO ESPECIAL €	1.049	1.249	1.899	1.999

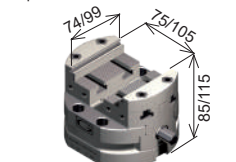

Elevador simple para mordaza Art.640 MONTAJE INCLUIDO

Art.641H	1	2	3x166	3x266
Tipo	1	2	3x166	3x266
Ref.	7.64.1H100AL /100	7.64.1H200AL /100	7.64.1H3166AL /100	7.64.1H3266AL /100
PRECIO €	640	753	769	1.167
PRECIO ESPECIAL €	400	450	600	900

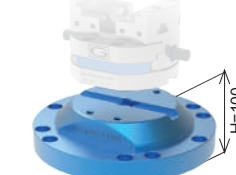

Elevadores de acero con punto cero para Art.640 para cambio rápido. Equipamiento estándar: 1 perno de tracción Art.10S / 11S, 1 tapón de teflón con junta tórica Art.9, 1 pasador de posicionamiento Art.640P, 1 tornillo calibrado sin cabeza Art.79.

Art.63	1	2	Art.64
Tipo	1	2	2
Altura H	100	125	163
Ref.	9.63.10000	9.63.20000	9.64.20000
LIST PRICE €	1.222	2.066	3.448
PRECIO ESPECIAL €	949	1.449	-

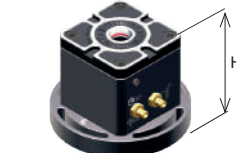

Art.645B
Mordaza lisa

Tipo	Ref.	PRECIO €	PRECIO ESPECIAL €
1	6.64.5B100	102	77
2	6.64.5B200	122	93
3	6.64.5B300	159	121



Art.645C
Mordaza pulida

Tipo	Ref.	PRECIO €	PRECIO ESPECIAL €
1	6.64.5C100	102	77
2	6.64.5C200	122	93
3	6.64.5C300	159	121



Art.645D
Mordaza dentada

Tipo	Ref.	PRECIO €	PRECIO ESPECIAL €
1	6.64.5D100	102	77
2	6.64.5D200	122	93
3	6.64.5D300	159	121



Art.645E
Mordaza con paso

Tipo	Ref.	PRECIO €	PRECIO ESPECIAL €
1	6.64.5E100	115	87
2	6.64.5E200	134	102
3	6.64.5E300	171	130



Art.645F
Mordaza prismática

Tipo	Ref.	PRECIO €	PRECIO ESPECIAL €
1	6.64.5F100	129	98
2	6.64.5F200	146	111
3	6.64.5F300	185	141



Art.645T
Mordaza de sujeción (Bajo pedido)

Tipo	Ref.	PRECIO €	PRECIO ESPECIAL €
1	6.64.5T100	129	98
2	6.64.5T200	146	111
3	6.64.5T300	185	141

TORRETAS

Fundición maciza con doble tratamiento térmico de distensión - Perfectas para centros de mecanizado horizontales

ESTÁNDAR JAPONÉS

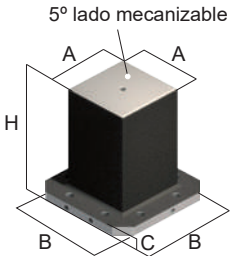

Art.53B

Ref.	A	B	C	D	H	Kg	PRECIO €	PRECIO ESPECIAL €
8.53.B00080	260	400	45	-	550	197	1.853	1.550
8.53.B00081	260	400	45	-	660	228	2.139	1.690
8.53.B00100	260	500	45	-	650	255	2.417	2.000
8.53.B00105	260	500	45	-	750	284	2.505	2.000
8.53.B00115	310	500	45	-	900	383	3.551	2.700
8.53.B00171	360	500	45	-	700	356	3.328	2.500
8.53.B00180	360	630	45	-	820	452	4.217	3.200
*8.53.B00211	510	630	45	-	860	61	5.858	3.850

* Sólo para palets con ranura en "T"

Art.53B2 PLUS

Ref.	Kg	PRECIO €	PRECIO ESPECIAL €
8.53.B20080	182	2.361	1.950
8.53.B20081	204	2.680	2.050
8.53.B20100	238	3.027	2.400
8.53.B20105	254	3.138	2.500
8.53.B20115	354	4.311	3.300
8.53.B20171	326	4.041	3.050
8.53.B20180	427	5.277	4.200
8.53.B20211	593	7.113	4.350

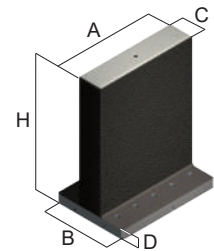

Art.55B

Ref.	A	B	C	D	H	Kg	PRECIO €	PRECIO ESPECIAL €
8.55.B00052	410	400	160	50	660	244	2.345	1.800
8.55.B00053	510	500	160	50	700	331	3.131	2.400
8.55.B00054	510	500	210	55	600	316	3.042	2.300
8.55.B00170	640	450	160	55	820	460	4.347	3.200
8.55.B00172	640	630	210	55	850	545	5.178	3.540
8.55.B00190	810	450	160	65	800	604	5.805	4.040

Art.55B2 PLUS

Ref.	Kg	PRECIO €	PRECIO ESPECIAL €
8.55.B20052	206	2.846	2.150
8.55.B20053	303	3.801	2.900
8.55.B20054	301	3.693	2.800
8.55.B20170	433	5.278	4.000
8.55.B20172	520	6.288	4.500
8.55.B20190	782	7.048	4.900

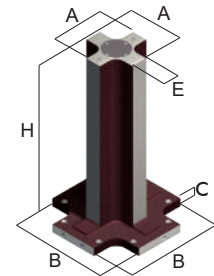

Art.57B

Ref.	A	B	C	D	H	Kg	PRECIO €	PRECIO ESPECIAL €
8.57.B00100	210	500	50	80	750	157	1.715	1.550
8.57.B00110	280	500	50	80	850	235	2.126	1.950
8.57.B00120	240	500	50	110	850	218	2.049	1.850
8.57.B00130	310	500	50	150	850	269	2.466	2.050
8.57.B00140	310	630	50	150	950	327	2.790	2.450

Art.57B2 PLUS

Ref.	Kg	PRECIO €	PRECIO ESPECIAL €
8.57.B20100	155	2.075	1.850
8.57.B20110	241	2.608	2.300
8.57.B20120	216	2.556	2.250
8.57.B20130	232	2.974	2.550
8.57.B20140	325	3.293	2.650

A Una pieza de fundición integral G30 integral, fresada con doble tratamiento térmico de distensión. Espesor de placa de 43-45 mm. Tolerancia: +12 / -5 mm.

B Fundición rugosa con base mecanizada y raspada a mano para sujeción directa sobre pallet estándar japonés. Base con 4 orificios de precisión Ø20F7 y roscas inferiores M16 con dimensiones de paso precisas para el uso de Punto Cero o para ser interfaz con otros pallets o placas. Listo para su instalación y para ser mecanizado para su reajuste con el eje de la máquina. Tolerancia +12 / -5 mm

C Cubo completamente acabado con un grosor de la placa aproximado de 38-40 mm. Tolerancia ± 0,02 mm

B2 PLUS Exceso de 1 mm en cada lado. Listo para instalar y mecanizar para reajustar con el eje de la máquina.

E Cubo integral con orificios calibrados y roscas macizas. Tolerancia ± 0,02 mm

F Cubo integral con casquillo templado 100 Cr6 y helicoidales de acero inoxidable. Tolerancia ± 0,02 mm

CUBO DE MORDAZA INTEGRAL CON PLACA BASE

Art.53B1

Cubo ligero
Base acabada

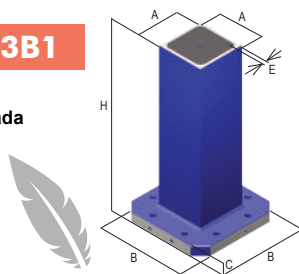

DESCUENTO HASTA EL
20%

Art.55B1

Torreta ligera de 2 lados
Base acabada



DESCUENTO HASTA EL
20%

A	B	C	E	H	Kg	Ref.	PRECIO €	PRECIO ESPECIAL €
210	400	45	25	750	167	8.53.B10055	1.853	1.500
260	400	45	25	850	229	8.53.B10085	2.235	1.800
260	500	45	25	750	234	8.53.B10105	2.439	1.950
360	500	50	30	900	400	8.53.B10182	3.453	2.700
360	630	45	30	950	468	8.53.B10185	4.135	3.250
460	630	45	35	950	634	8.53.B10205	5.161	4.250

E= Grosor de la placa

A	B	C	D	E	H	Kg	Ref.	PRECIO €	PRECIO ESPECIAL €
410	400	110	55	25	750	193	8.55.B10045	2.111	1.700
410	400	160	55	25	850	239	8.55.B10050	2.343	1.900
510	500	160	55	25	750	277	8.55.B10053	2.757	2.200
510	500	210	55	30	900	402	8.55.B10085	3.531	2.800
640	630	210	55	30	950	553	8.55.B10172	4.753	3.700

E= Grosor de la placa

Unidades & mesas PUNTO CERO

Tiempos de preparación reducidos en un 90%, repetibilidad dentro de 0,005 mm - Perfectas para centros de mecanizado verticales y horizontales

LA CLÁSICA NEUMÁTICA MÚLTIPLE



Art.664		CON BRIDA				
Tipo	Ref.	kN	Double Effect kN	PRECIO €	PRECIO ESPECIAL €	
1	9.66.41000	5,4	NOT AVAILABLE	632	499	
2	9.66.42000	10	NOT AVAILABLE	951	599	
3	9.66.43000	16	NOT AVAILABLE	1.194	999	

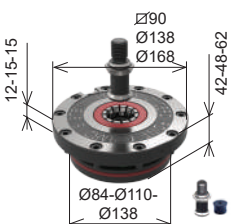

Art.665		CON BRIDA				
Tipo	Ref.	kN	Double Effect kN	PRECIO €	PRECIO ESPECIAL €	
1	9.66.51000	5,4	NOT AVAILABLE	509	399	
2	9.66.52000	10	NOT AVAILABLE	826	499	
3	9.66.53000	16	NOT AVAILABLE	1.075	899	

LA NEUMÁTICA HERMÉTICA SIMPLE

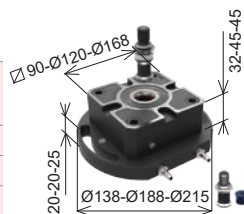

Art.664S		CON BRIDA		DOBLE EFECTO AIRE MUELLES		
Tipo	Ref.	kN	Double Effect kN	PRECIO €	PRECIO ESPECIAL €	
1	9.66.4S100	5,4	12,7	732	599	
2	9.66.4S200	10	27	1.037	699	
3	9.66.4S300	16	40	1.194	999	

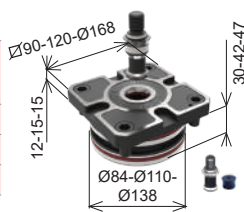

Art.665S		CON BRIDA		DOBLE EFECTO AIRE + MUELLES		
Tipo	Ref.	kN	Double Effect kN	PRECIO €	PRECIO ESPECIAL €	
1	9.66.5S100	5,4	12,7	610	499	
2	9.66.5S200	10	27	914	599	
3	9.66.5S300	16	40	1.075	899	

Equipamiento estándar: 1 tirador Art.11A, 1 tapón de teflón con junta tórica Art.9

Fuerza de sujeción: 5 + 40 kN / Fuerza de retención: más de 60 kN / Desbloqueo neumático: 6 + 14 bar / Compensación axial y radial gracias a la pinza elástica integral / Centrado doble tirador para máxima rigidez / Limpieza con aire / Solo para PUNTO CERO ÚNICO (versión S): 4 RANURAS y FUNCIÓN DE EFECTO DOBLE

KIT PUNTO CERO NEUMÁTICO PLACAS BASE INTERCONECTADAS

KIT #1 Y #2 POSICIONAMIENTO Y BLOQUEO INCLUIDOS

KIT #3 Y #4 POSICIONAMIENTO Y BLOQUEO ESTÁNDAR INCLUIDOS, BLOQUEO ESPECÍFICO EXTRA*

KIT #1 CNC VERTICAL

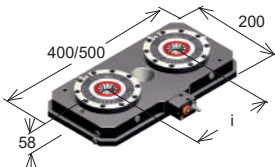

Art.81P PLACA BASE	PRECIO €	PRECIO ESPECIAL €
200x400 (i=200)	2.724	1.599
200x500 (i=250)	2.793	1.699

KIT #2 CNC HORIZONTAL

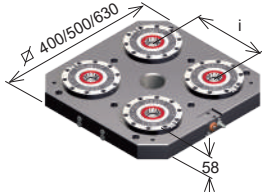

Art.80P PLACA BASE	PRECIO €	PRECIO ESPECIAL €
400x400 (i=200)	4.880	3.299
500x500 (i=250)	5.107	3.499
630x630 (i=300)	5.595	3.999

KIT #3 CNC VERTICAL

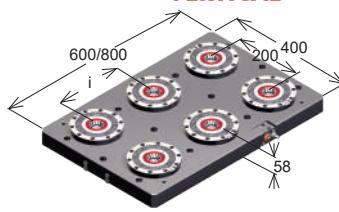

Art.81P BASE PLATE	PRECIO €	PRECIO ESPECIAL €
400x600 (i=200)	7.035	4.699
400x800 (i=300)	7.332	4.899

KIT #4 CNC 5 EJES

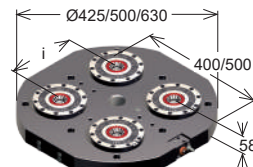

Art.82P ROUND BASE PLATE	PRECIO €	PRECIO ESPECIAL €
Ø425 (i=200)	5.107	3.399
Ø500 (i=250)	5.085	3.499
Ø630 (i=300)	5.674	3.999

PLACAS DE INTERFAZ PARA PLACAS BASE DE PUNTO CERO

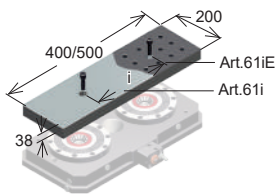

Art.61iC LISO	PRECIO €	PRECIO ESPECIAL €
200x400 (i=200)	936	599
200x500 (i=250)	1.006	649

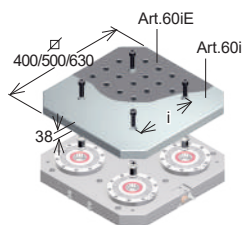

Art.60iC LISO	PRECIO €	PRECIO ESPECIAL €
400x400 (i=200)	1.146	863
500x500 (i=250)	1.380	1.039
630x630 (i=300)	1.730	1.303

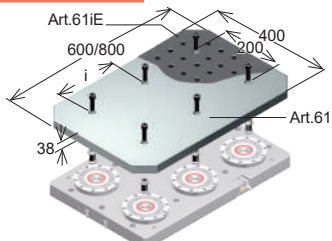

Art.61iC LISO	PRECIO €	PRECIO ESPECIAL €
400x600 (i=200)	1.753	1.320
400x800 (i=300)	2.337	1.760

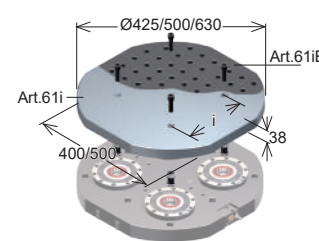

Art.62iC LISO	PRECIO €	PRECIO ESPECIAL €
Ø425 (i=200)	1.228	924
Ø500 (i=250)	1.402	1.056
Ø630 (i=300)	1.636	1.232

Art.61iE MATRIZ INTEGRADA	PRECIO €	PRECIO ESPECIAL €
200x400 (i=200)	1.135	649
200x500 (i=250)	1.250	749

Art.60iE MATRIZ INTEGRADA	PRECIO €	PRECIO ESPECIAL €
400x400 (i=200)	1.505	1.040
500x500 (i=250)	1.968	1.360
630x630 (i=300)	3.090	2.136

Art.61iE MATRIZ INTEGRADA	PRECIO €	PRECIO ESPECIAL €
400x600 (i=200)	2.083	1.440
400x800 (i=300)	2.962	2.048

Art.62iE MATRIZ INTEGRADA	PRECIO €	PRECIO ESPECIAL €
Ø425 (i=200)	1.505	1.040
Ø500 (i=250)	1.921	1.328
Ø630 (i=300)	2.569	1.776

Mordazas GRIP MATIC

Mordaza hidráulica o neumática doble efecto - Ideal para centros de mecanizado de 5 ejes

Art.670



Escanea el código QR y descubre más información



Equipamiento estándar: - 4x Tornillos calibrados (Art.83) - Pasador de centrado (Art.670P) - 2 Niplon o 2 Art.PN04 - Válvula sin retorno (Art.PN16)



Mordaza con base neumática o hidráulica, perfecta para centros de mecanizado de 5 ejes.

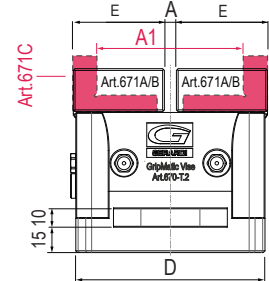
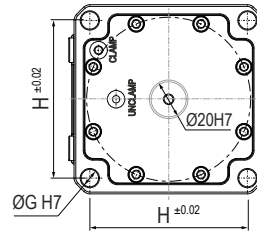
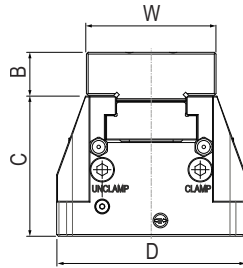

Tipo	Anchura boca W	Apertura Min. A	Apertura Max. A1	Altura mordaza C+B	Altura base C	Longitud base D	Longitud boca E	Orificios de centrado y fijación del paso H	NEUMÁTICA		HIDRÁULICA		PRECIO €	PRECIO ESPECIAL €		
									Presión de aire	Fuerza de sujeción	ART.670 NEUMÁTICA Ref.	Presión			Fuerza de sujeción	ART.670 HIDRÁULICA Ref.
2	74	6,4	88,9	105	80	106	52	90	Max 10BAR	7 kN	7.67.0PN20	30BAR	19 kN	7.67.0ID20	1.790	1.400
3	99	8,5	130,2	135	105	166	78	140		14,4 kN	7.67.0PN30	30BAR	37,5 kN	7.67.0ID30	2.387	1.850
4	124	12	162	165	130	206	96	170		16,9 kN	7.67.0PN40	25 BAR	47 kN	7.67.0ID40	3.162	2.400

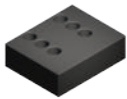

Art.671A
Boca lisa



Art.671B
Boca estrecha lisa



Art.671C
Mordaza para placas de mordaza estándar de ancho estrecho



Art.243
Placa de mordaza recta ranurada endurecida



Art.245
Placa de mordaza recta lisa templada



Art.247G
Placa recta con placas GRIP

PLACA DE INTERFAZ PARA MORDAZAS GRIP MATIC - PERFECTA PARA CENTROS DE 5 EJES

Art.670CP SEMI-AUTOMÁTICA

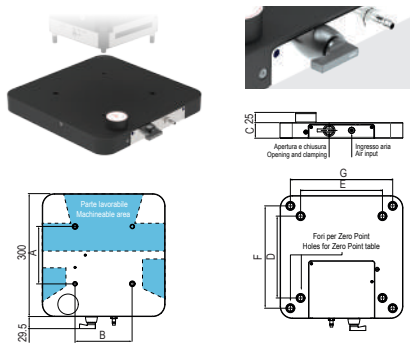

Placa de interfaz para mordaza GripMatic Art.670PN acoplamiento rápido semiautomático con entrada de aire y control manual del sistema a través de un selector.

Tipo	Paso de los orificios A	Paso de los orificios B	Atura de la placa C	Paso de los orificios (Punto Cero) D	Paso de los orificios (Punto Cero) E	Paso de los orificios (Punto Cero) F	Paso de los orificios (Punto Cero) G	Presión del aire	Fuerza de sujeción	Ref.	PRECIO €
2	90	90	38	200	200	250	250	Max 10BAR	7 kN	7.67.0CP20	2.271
3	140	140	38	200	200	250	250		14,4 kN	7.67.0CP30	2.271
4	170	170	38	200	200	250	250		16,9 kN	7.67.0CP40	2.271

Art.670AP AUTOMÁTICA



Placa de interfaz para mordaza GripMatic Art.670PN automática con entrada de aire a través de la mesa de la máquina y posibilidad de ser controlado directamente por el CNC. Esta placa puede ser totalmente adaptada según las características de la máquina (control de posicionamiento de la pieza y limpieza).

* Precio mínimo, PERSONALIZACIÓN INCLUIDA

PLACA 100% PERSONALIZABLE

Tipo	Presión del aire	Fuerza de sujeción	ART.670 Neumática Ref.	PRECIO €*
2	Max 10BAR	7 kN	7.67.0AP20	2.497
3		14,4 kN	7.67.0AP30	2.497
4		16,9 kN	7.67.0AP40	2.497

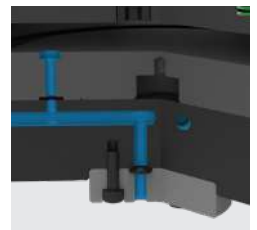

DUODUX

Plato autocentrante doble guía



DIN
6350

Equipamiento estándar: 1 juego de 3 mordazas interiores, 1 juego de 3 mordazas exteriores, 1 llave para apertura de mordazas

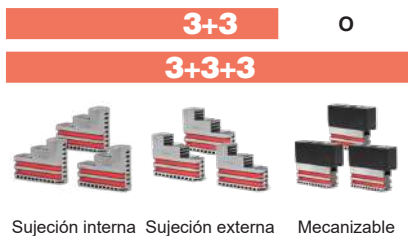

Sujeción interna Sujeción externa Mecanizable

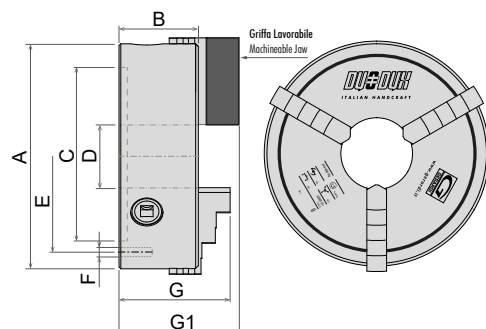

	A	B	C h6	D	E	F	G	G1	daN	Rpm
GUÍA ÚNICA	Ø160	70,5	130	42	144,5	N°3 M8	89,5	106	3.100	Max 3.600
DOBLE GUÍA	Ø200	81	160	53	176	N°3 M10	113	132,5	3.700	Max 3.000
DOBLE GUÍA	Ø250	88,5	200	80	224	N°6 M12	124	149,5	4.600	Max 2.500
DOBLE GUÍA	Ø310	100,5	260	108	286	N°3 M12	143,5	162,5	5.500	Max 2.000
DOBLE GUÍA	Ø365	105,5	310	126,5	336,5	N°6 M14	155	168	5.900	Max 1.800
DOBLE GUÍA	Ø430	114	382	170	405	N°6 M14	170	176,5	6.900	Max 1.400

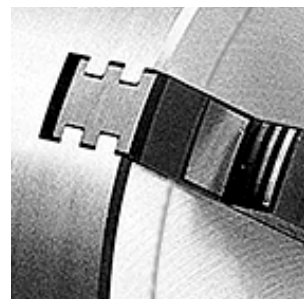

	3+3				3+3+3				
	A	Kg	Ref.	PRECIO €	PRECIO ESPECIAL €	Kg	Ref.	PRECIO €	PRECIO ESPECIAL €
GUÍA ÚNICA	Ø160	8	GMD-160-3G20	1.067	854	10	GMD-160-3G30	1.333	1.066
DOBLE GUÍA	Ø200	15	GDD-200-3G20	1.156	925	18	GDD-200-3G30	1.444	1.155
DOBLE GUÍA	Ø250	23	GDD-250-3G20	1.358	1.086	27	GDD-250-3G30	1.650	1.320
DOBLE GUÍA	Ø310	38	GDD-310-3G20	1.984	1.587	44	GDD-310-3G30	2.319	1.855
DOBLE GUÍA	Ø365	61	GDD-365-3G20	3.092	2.474	71	GDD-365-3G30	3.760	3.008
DOBLE GUÍA	Ø430	92	GDD-430-3G20	4.345	3.476	103	GDD-430-3G30	5.180	4.144



PRECISIÓN, RIGIDEZ Y ESTABILIDAD TAMBIÉN DURANTE EL MECANIZADO DE ALTO RENDIMIENTO

DUO-DUX, el plato manual autocentrante de doble guía. Está realizado con mordazas integrales de doble guía, que soportan cargas más pesadas y garantizan una mayor estabilidad. La corona está rectificadora de una manera especial estudiada por Gerardi para garantizar la máxima precisión y repetibilidad. Cada plato DUO-DUX está equilibrado según las normas ISO3089/74 y se suministra con los certificados de garantía y de prueba. Los platos con diámetro 365 y 430mm, adecuados para mecanizados pesados, mantienen las mismas características técnicas y precisión de los platos con diámetros inferiores.

ALTA RIGIDEZ

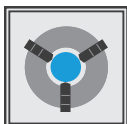

5 AÑOS DE GARANTÍA



CUERPO DE FUNDICIÓN DE HIERRO



Modelo especial
Ø270-105

No sólo dimensiones estándar: también está disponible una versión especial de Ø270mm con soporte de barra aumentado Ø105.

Ref. GDD-270-3G20-105



Mordazas integrales

Las mordazas de sujeción integrales están fabricadas en acero al cromo-níquel endurecido para ofrecer la máxima precisión y repetibilidad.



Double guide

El sistema de doble guía de platos autocentrantes Duo Dux puede soportar una mayor carga de trabajo y garantizar una mayor estabilidad.



5 Años de garantía

Seguros de la fiabilidad y alta calidad de todos los componentes de los platos autocentrantes DuoDux, reconocemos 5 años de garantía en toda la gama.

Portaherramientas ESTÁTICO

Ahorra comprando portaherramientas estáticos - Elige entre una amplia gama en el catálogo



ESCAÑA EL CÓDIGO QR Y ELIGE ENTRE UNA AMPLIA GAMA DEL CATÁLOGO

DIN 69880

DMG MORI

Mazak

LOKUMA

BMT

Bolt Mounted Turret



Nakamura-Tome



TSUGAMI CORPORATION

Solicita la contraseña a tu proveedor

EJEMPLO KIT 1

3 PCS

DESCUENTO HASTA EL
10%

EJEMPLO KIT 2

4 PCS

DESCUENTO HASTA EL
15%

COMPRANDO 3 HERRAMIENTAS ESTÁTICAS

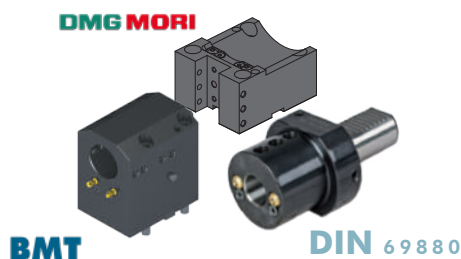

COMPRANDO 4 HERRAMIENTAS ESTÁTICAS

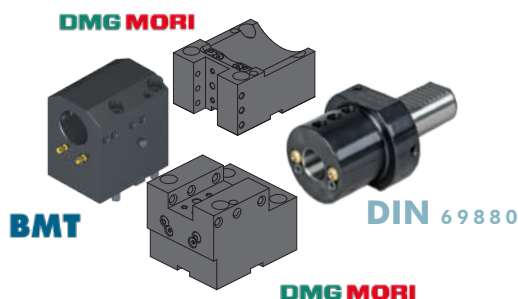

ADAPTADORES de cambio rápido universal

Nuevos tipos 2.0 - Compatibles con todas las salidas er

DESCUENTO HASTA EL
50%



¡HASTA FIN DE EXISTENCIAS!

Tuerca de rodamiento de bolas

Plato de extracción de diamante

PATENTADO

PLATO DE EXTRACCIÓN DE DIAMANTE

Tuerca de rodamiento de bolsa

Plato de extracción de diamante



PRECIO 425€ CADA UNO

- Reducción del tiempo de preparación y posibilidad de preajuste de herramientas fuera de línea.
- Adaptador modular universal de cambio rápido de ALTO PAR.
- Sistema modular de portaherramientas adecuado para cada salida de pinza ER de herramienta accionada.
- Mayor rigidez y rendimiento garantizados en herramientas motorizadas Gerardi gracias a la placa de diamante extraíble y a la tuerca con rodamiento de bolas.
- Todos los adaptadores modulares de cambio rápido 2.0 son adecuados para portaherramientas ER con suministro de refrigerante externo e interno.
- Utilizando los adaptadores de cambio rápido, sugerimos no superar las 10.000 Rpm.

3 PCS

4 PCS

WOOW

COMPRANDO
3 CAMBIOS RÁPIDOS UNIVERSALES
(TUERCAS INTERNAS O EXTERNAS)

COMPRANDO
4 CAMBIOS RÁPIDOS UNIVERSALES
(TUERCAS INTERNAS O EXTERNAS)

COMPRANDO 1 HERRAMIENTA
MOTORIZADA, SALIDA ER25, ER32 o ER40
1 ADAPTADOR DE CAMBIO RÁPIDO A ELEGIR
(TUERCAS INTERNAS O EXTERNAS)



DESCUENTO HASTA EL
20%

DESCUENTO HASTA EL
25%

DESCUENTO HASTA EL
50%

En el cambio rápido



Portaherramientas MOTORIZADOS

Herramientas motorizadas para tornos CNC - ¡Actualiza tu torno y aumente la productividad!

ALTO RENDIMIENTO
MODELOS DISPONIBLES
(+ PAR, + RPM)

BMT

Bolt Mounted Turret

COMPATIBLE CON

DOOSAN / HARDINGE / SAMSUNG / HWACHEON / HYUNDAI WIA / VICTOR / HAAS

IBMT 65 TAMBIÉN COMPATIBLE CON TORNOS HAAS!

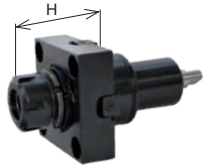

80
BAR

Axial

BMT	Ref.	ER	H Max	Nm	Rpm	PRECIO €	PRECIO ESPECIAL €
45	99.DS.A03	25	57,2	35	8000	1.033	839
	99.DS.A04	25	57,2	35	8000	1.179	929
55	99.DS.A01	25	57,2	40	8000	1.363	899
	99.DS.A02	25	57,2	40	8000	1.243	979
65 HAAS READY!	99.DS.A41	32	72,5	70	6000	1.274	1.049
	99.DS.A42	32	72,5	70	6000	1.465	1.179
75	99.DS.A34	40	90,2	100	6000	1.497	1.249
	99.DS.A35	40	90,2	100	6000	1.720	1.399



80
BAR

Radial

BMT	Ref.	ER	H	Nm	Rpm	PRECIO €	PRECIO ESPECIAL €
45	99.DS.A07C	25	65	35	8000	1.822	1.499
	99.DS.A08C	25	65	35	8000	2.190	1.799
55	99.DS.A11C	25	70	40	8000	2.038	1.599
	99.DS.A12C	25	70	40	8000	2.408	1.899
65 HAAS READY!	99.DS.A51C	32	72	70	6000	2.140	1.699
	99.DS.A52C	32	72	70	6000	2.534	1.999
75	99.DS.A38C	40	60	100	6000	3.311	2.649
	99.DS.A39C	40	60	100	6000	3.973	3.099



80
BAR

Ajustable

BMT	Ref.	ER	H	Nm	Rpm	PRECIO €	PRECIO ESPECIAL €
45	99.DS.A16	20	65	15	8000	4.698	3.899
	99.DS.A17	20	65	15	8000	6.111	4.699
55	99.DS.A23	20	65	15	8000	4.698	3.899
	99.DS.A66	20	65	15	8000	6.111	4.699
65 HAAS READY!	99.DS.A64	25	75	25	6000	5.221	4.299
	99.DS.A65	25	75	25	6000	6.748	5.199
75	99.DS.A47	25	75	25	6000	5.221	4.299
	99.DS.A48	25	75	25	6000	6.748	5.199

Disponibles en los dos sentidos de giro del cabezal de la máquina

FIJACIÓN BMT CON ESPIGA ESTÁNDAR

Versión de alto rendimiento con espiga más grande disponible bajo pedido

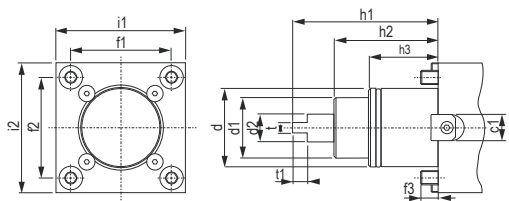

BMT	c1	d	d1	d2	f1	f2	f3	h1	h2	h3	i1	i2	t	t2	h4	N	ØM
45	15	Ø45	35	14	58	58	10	84	60	40	75	75	6	8,5	-	-	-
55	15	Ø55	40	16	64	64	14	104	75	30	85	85	8	8,5	9,5	8	29
65	18	Ø65	45	18	70	73	15	112	83	32	94	94	10	14	15	10	29
75	25	Ø75	55	23	90	90	15	110	80	43	112	112	14	15	-	-	-
85	25	Ø85	65	33,5	100	100	18	140	100	43	125	125	16	20	-	-	-

OFERTA ESPECIAL EN LA NUEVA GAMA DE HERRAMIENTAS MOTORIZADAS

Mazak QTN3

QUICK TURN NEXUS QTN
300 / 350 / 400 / 450 -
SQT 28 / 30 - 300

80
BAR

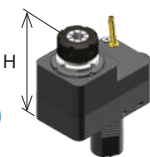

Eje de desviación

Cod.	ER	H	Nm	Rpm	PRECIO €	PRECIO ESPECIAL €
99.MZ.A71	40	145	100	4000	3.320	3.100
99.MZ.A72	40	145	100	4000	3.631	3.300

Mazak QTN2

QUICK TURN NEXUS
QTN 200 / 250
SUPER QUADREX TURN
SQT 15/18 - 200 / 250

80
BAR

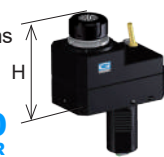

Cod.	ER	H	Nm	Rpm	PRECIO €	PRECIO ESPECIAL €
99.MZ.A58	32	120	80	6000	2.491	1.549
99.MZ.A59	32	120	80	6000	3.010	2.100

Mazak SMART QTS1

QUICK TURN SMART
QTS 100M / 200M
QT COMPACT 100M -
200M - 300M

80
BAR



Cod.	ER	H Max	Nm	Rpm	PRECIO €	PRECIO ESPECIAL €
99.MZ.A03	32	70	60	6000	1.972	1.749
99.MZ.A06	32	70	60	6000	2.387	2.149

Radial

80
BAR



Cod.	ER	H	Nm	Rpm	PRECIO €	PRECIO ESPECIAL €
99.MZ.A75	40	160	100	4000	3.424	3.200
99.MZ.A81	40	160	100	4000	3.943	3.600

80
BAR

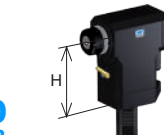

Cod.	ER	H	Nm	Rpm	PRECIO €	PRECIO ESPECIAL €
99.MZ.A65	32	120	80	6000	2.698	1.649
99.MZ.A66	32	120	80	6000	2.906	1.949

80
BAR



Cod.	ER	H	Nm	Rpm	PRECIO €	PRECIO ESPECIAL €
99.MZ.A09	32	80	60	6000	2.698	2.299
99.MZ.A10	32	80	60	6000	2.906	2.599

Sentido de giro opuesto al cabezal de la máquina

Sentido de giro opuesto al cabezal de la máquina



Portaherramientas **MOTORIZADOS**

Herramientas motorizadas para tornos CNC - ¡Actualiza tu torno y aumenta la productividad!

ALTO RENDIMIENTO
MODELOS DISPONIBLES
(+ PAR, + RPM)

DIN 5480

VDI - DIN69880

* En caso de pedido especificar siempre orientación izq. o dcha.



d1	Ref.	ER	H	Nm	Rpm	PRECIO €	PRECIO ESPECIAL €
30	99.ST.8003	25	66	32	6000	917	779
	99.ST.8011	25	66	32	6000	1.185	979
40	99.ST.8005	32	95	63	6000	1.147	999
	99.ST.8013	32	95	63	6000	1.499	1.229

🔄 Sentido de giro igual que el cabezal de la máquina

30	99.ST.8030	25	55	32	6000	1.926	1.599
	99.ST.8038	25	55	32	6000	2.216	1.829
40	99.ST.8033	32	100	63	6000	2.436	1.999
	99.ST.8041	32	100	63	6000	2.798	2.299

🔄 Sentido de giro opuesto al cabezal de la máquina



DIN 5482

VDI - DIN69880

* En caso de pedido especificar siempre orientación izq. o dcha.



d1	Ref.	ER	H	Nm	Rpm	PRECIO €	PRECIO ESPECIAL €
30	99.ST.8201	25	94	32	6000	865	779
	99.ST.8207	25	94	32	6000	1.161	979
40	99.ST.8203	32	115	63	5000	1.041	899
	99.ST.8208	32	115	63	5000	1.347	1.129

🔄 Sentido de giro igual que el cabezal de la máquina

30	99.ST.8217	25	55	32	6000	1.735	1.449
	99.ST.8223	25	55	32	6000	2.025	1.699
40	99.ST.8220	32	100	63	5000	2.078	1.699
	99.ST.8226	32	100	63	5000	2.430	1.999

🔄 Sentido de giro opuesto al cabezal de la máquina

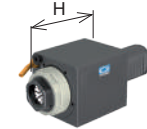

VDI - DIN69880

* En caso de pedido especificar siempre orientación izq. o dcha.



d1	Ref.	ER	H	Nm	Rpm	PRECIO €	PRECIO ESPECIAL €
30	99.BF.0003	25	94	32	6000	895	779
	99.BF.0010	25	94	32	6000	1.193	979
40	99.BF.0005	32	117	63	5000	1.079	929
	99.BF.0011	32	115	63	5000	1.391	1.179

🔄 Sentido de giro igual que el cabezal de la máquina

30	99.BF.0021	25	55	32	6000	1.781	1.499
	99.BF.0027	25	55	32	6000	2.086	1.749
40	99.BF.0024	32	100	63	5000	2.140	1.749
	99.BF.0030	32	100	63	5000	2.506	2.049

🔄 Sentido de giro opuesto al cabezal de la máquina

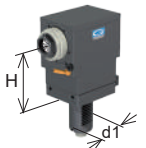

DIN 1809

VDI - DIN69880

* En caso de pedido especificar siempre orientación izq. o dcha.



d1	Ref.	ER	H	Nm	Rpm	PRECIO €	PRECIO ESPECIAL €
30	99.DP.0903	25	94	32	6000	865	779
	99.DP.0910	25	94	32	6000	1.161	979
40	99.DP.0905	32	115	63	5000	1.041	879
	99.DP.0911	32	115	63	5000	1.347	1.129

🔄 Sentido de giro igual que el cabezal de la máquina

30	99.DP.0919	25	55	32	6000	1.735	1.449
	99.DP.0925	25	55	32	6000	2.025	1.699
40	99.DP.0922	32	100	63	5000	2.078	1.699
	99.DP.0928	32	100	63	5000	2.430	1.999

🔄 Sentido de giro opuesto al cabezal de la máquina

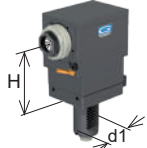

BMT 55

CUERPO MACIZO NIQUELADO



d1	Ref.	Biglia Ref.	ER	H	Nm	Rpm	PRECIO €	PRECIO ESPECIAL €
55	99.BG.A01	10.57.88.00	25	70	47	6000	887	699
	99.BG.A02	T.134-00061	32	70	47	6000	887	699
	99.BG.A03	T.134-00071	32	70	47	6000	1.227	949

🔄 Sentido de giro igual que el cabezal de la máquina

d1	Ref.	Biglia Ref.	ER	H	Nm	Rpm	PRECIO €	PRECIO ESPECIAL €
55	99.BG.A05	10.57.87.00	25	70	47	6000	1.661	1.249
	99.BG.A06	T.134-00062	32	70	47	6000	1.661	1.249
	99.BG.A07	T.134-00072	32	70	47	6000	2.179	1.649
	99.BG.A08	T.134-00076	25	100	47	6000	1.868	1.399
	99.BG.A09	T.134-00077	32	100	47	6000	1.868	1.399
	99.BG.A10	T.134-00088	32	100	47	6000	2.179	1.649

🔄 Sentido de giro igual que el cabezal de la máquina

d1	Ref.	Biglia Ref.	ER	H	Nm	Rpm	PRECIO €	PRECIO ESPECIAL €
55	99.BG.A15	T.134-00025	16	60	16	6000	3.830	2.849
	99.BG.A16	T.134-00057	20	60	16	6000	3.830	2.849

🔄 Sentido de giro igual que el cabezal de la máquina

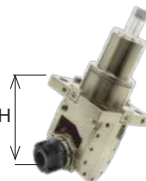
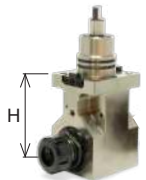

NLX 1500 - 2000 - 2500 - 3000

12 Posiciones

NZX 12 Posiciones



Ref.	ER	H Max	Nm	Rpm	PRECIO €	PRECIO ESPECIAL €
99.MS.A59	32	89,9	60	10.000	1.249	999
99.MS.A60	32	89,9	60	10.000	1.847	1.429
99.MS.A62	40	92	60	10.000	1.249	999
99.MS.A63	40	92	60	10.000	1.847	1.429
99.MS.A72	32	90	60	10.000	2.674	2.099
99.MS.A73	32	90	60	10.000	2.993	2.349
99.MS.A76	40	90	60	10.000	2.674	2.099
99.MS.A77	40	90	60	10.000	2.993	2.349

🔄 Disponible en los dos sentidos de giro del cabezal de la máquina

NZ 1500 - 2000 - 3100 - 3150 - 3200

16 Positions



Ref.	ER	H Max	Nm	Rpm	PRECIO €	PRECIO ESPECIAL €
99.MS.A101	25	84,3	50	12.000	1.249	1.049
99.MS.A102	25	84,3	50	12.000	1.847	1.479
99.MS.A103	32	89,2	50	12.000	1.249	1.049
99.MS.A104	32	89,2	50	12.000	1.847	1.479

🔄 Sentido de giro igual que el cabezal de la máquina

99.MS.A106	25	85	50	12.000	2.674	2.099
99.MS.A107	25	85	50	12.000	2.993	2.349
99.MS.A108	32	85	50	12.000	2.674	2.099
99.MS.A109	32	85	50	12.000	2.993	2.349

🔄 Sentido de giro opuesto al cabezal de la máquina

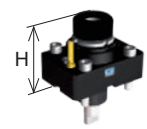



Portaherramientas MOTORIZADOS

Herramientas motorizadas para tornos CNC - ¡Actualiza tu torno y aumente la productividad!

ALTO RENDIMIENTO
MODELOS DISPONIBLES
(+ PAR, + RPM)



VDI 40

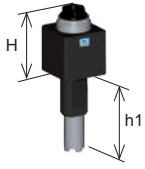

Ref.	ER	H	h1	Nm	Rpm	PRECIO €	PRECIO ESPECIAL €
99.HA.590082	32	75	117,5	63	6000	945	749
99.HA.590082B	32	75	117,5	63	6000	1.179	899
99.HA.590083	32	75	104,8	63	6000	945	749
99.HA.590083B	32	75	104,8	63	6000	1.179	899
99.HA.596352	32	75	130,25	63	6000	945	749
99.HA.596352B	32	75	130,25	63	6000	1.179	899

⌚ Sentido de giro igual que el cabezal de la máquina



* Acoplamientos intercambiables para cualquier tipo de torreta Haas

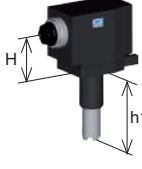

Ref.	ER	H	h1	Nm	Rpm	PRECIO €	PRECIO ESPECIAL €
99.HA.590084	32	75	117,5	63	6000	1.773	1.349
99.HA.590084B	32	75	117,5	63	6000	2.240	1.699
99.HA.590085	32	75	104,8	63	6000	1.773	1.349
99.HA.590085B	32	75	104,8	63	6000	2.240	1.699
99.HA.596353	32	75	130,25	63	6000	1.773	1.349
99.HA.596353B	32	75	130,25	63	6000	2.240	1.699

⌚ Sentido de giro igual que el cabezal de la máquina



Ø45: WT100 -TW1 Ø54: WT100 -TW1

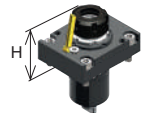

d1	Ref.	ER	H Max	Nm	Rpm	PRECIO €	PRECIO ESPECIAL €
45	99.MY.A02	25	57,6	35	6000	853	749
	99.MY.A03	25	57,6	35	6000	1.022	899
54	99.MY.A09	32	79,4	60	6000	993	849
	99.MY.A10	32	79,4	60	6000	1.140	949
45	99.MY.A05	25	65	35	6000	1.506	1.249
	99.MY.A06	25	65	35	6000	2.456	1.649
54	99.MY.A11	32	75	60	6000	2.284	1.899
	99.MY.A12	32	75	60	6000	2.207	1.849

⌚ Sentido de giro opuesto al cabezal de la máquina



BMT44 WT100 -TW1 BMT55 SUPER NTJX-NTJM 3/TMC 18/ TW10/SC150-250/WT150-250/WTW 150/WTS 150/WT100



d1	Ref.	ER	H Max	Nm	Rpm	PRECIO €	PRECIO ESPECIAL €
45	99.NK.A40	25	57,2	40	6000	946	799
	99.NK.A43	25	57,2	40	6000	1.081	899
55	99.NK.A03	32	72,2	63	6000	993	849
	99.NK.A04	32	72,2	63	6000	1.530	1.299
45	99.NK.A50	25	60	40	6000	1.676	1.399
	99.NK.A53	25	60	40	6000	2.008	1.699
55	99.NK.A13	32	55	63	6000	1.868	1.549
	99.NK.A14	32	55	63	6000	2.519	2.099



BMT60: SPACE TURN LB 200EX/LB 2500EX/LB3000EX/GENOS SERIES L300-MW/ MULTUS U3000/U40007/LU3000EX M/MY

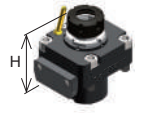

d1	Ref.	ER	H Max	Nm	Rpm	PRECIO €	PRECIO ESPECIAL €
60	99.OK.A80	32	79	60	6000	1.687	1.299
	99.OK.A81	32	79	60	6000	2.141	1.599

⌚ Sentido de giro igual que el cabezal de la máquina



60	99.OK.A82	32	70	60	6000	3.048	2.299
	99.OK.A83	32	70	60	6000	3.631	2.749

⌚ Sentido de giro opuesto al cabezal de la máquina



VDI40 OKUMA CAPTAIN L370 M - ES L10 M - GENOS L300, L3000-E M/MY (VDI40) LB 300 MW - LB/LU 300 MY - LB/LU 300, 3000 M (VDI40)



Axial



Ref.	ER	H	Nm	Rpm	PRECIO €	PRECIO ESPECIAL €
99.OK.A18	32	98,6	70	6000	1.947	1.499
99.OK.A23	32	98,6	70	6000	2.465	1.899

Radial

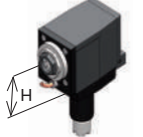

99.OK.A19	32	70	60	6000	3.373	2.549
99.OK.A25	32	70	60	6000	4.151	3.149



BMT60 EX 380 / 310 / 508 / 510 / 708 / 710 / 910 - EX 2000 M/Y - TC 350 MC - TT 350 MC - NEX 108/110/908/910 - LA 200/250 M/Y - LA 250 YS (15 stations) - FX 800 - MX 800 - VTL 450 M - LX 2500 M/Y



Axial

Ref.	ER	H	Nm	Rpm	PRECIO €	PRECIO ESPECIAL €
99.TK.A12	32	93	50	6000	1.499	1.149
99.TK.A13	32	93	50	6000	2.213	1.699

Radial

99.TK.A02	32	90	50	6000	3.139	2.399
99.TK.A05	32	90	50	6000	3.333	2.549

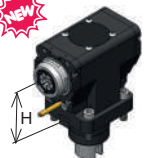

BMT65: M06D/M06SD/M06SY/M08SD/M08SY



Axial

Cod.	ER	H Max	Nm	Rpm	PRECIO €	PRECIO ESPECIAL €
99.TS.A01	25	60	40	8000	1.558	1.099
99.TS.A03	32	60	40	8000	2.141	1.499
99.TS.A02	25	60	40	8000	2.141	1.499
99.TS.A04	32	60	40	8000	2.141	1.499

Radial

99.TS.A08	25	65	40	8000	2.529	1.749
99.TS.A10	32	65	40	8000	3.112	2.199
99.TS.A09	25	65	40	8000	3.112	2.199
99.TS.A11	32	65	40	8000	3.112	2.199



CABEZALES ANGULARES & Aceleradores del CABEZAL

iNovedad! ii Ahora también cabezas angulares de línea clásica a un PRECIO ESPECIAL !!

EQUIPAMIENTO ESTÁNDAR

Bolsa especial / Tope / Tuerca ER / Llaves / Tubo de grasa / Libro de instrucciones

Ve a la página del catálogo para saber más



ISO / 40
CAT / 50
BT / 50



Ratio
1:1



Rpm
8.000



Kg 5,4



ER25
Ø1/16

LÍNEA CLÁSICA ATC

G90-16

PRECIO ~~€ 3.598~~
PRECIO ESPECIAL: € 3.000

EQUIPAMIENTO ESTÁNDAR

Bolsa especial / Tope / Tuerca ER / Llaves / Tubo de grasa / Libro de instrucciones

Ve a la página del catálogo para saber más



ISO / 50
CAT / 50
BT / 50



Ratio
1:1



Rpm
4.000



Kg 11



ER32
Ø2/20

LÍNEA CLÁSICA ATC

G90-20

PRECIO ~~€ 3.604~~
PRECIO ESPECIAL: € 3.200



AMPLIA GAMA DE CABEZALES ANGULARES

Casi 200 tipos de cabezales angulares clásicos disponibles

MÁXIMA RIGIDEZ

Gracias al vástago integral y al eje fabricados en una sola pieza

CUERPO AUSTABLE 360°

Máxima rigidez y resistente a la corrosión. Expansión térmica mínima.

RODAMIENTOS DE BOLAS ABEC 9

Rodamientos de contacto angular precargados con lubricación con grasa de larga duración.

ENGRANAJES GLEASON

Garantiza menos calentamiento y ruido y las Rpm más altas.

EQUIPAMIENTO ESTÁNDAR

Bolsa especial / Tope / Tuerca ER / Llaves / Tubo de grasa / Libro de instrucciones

Ve a la página del catálogo para saber más



ISO / 40
CAT / 50
BT / 50



Ratio
1:1



Rpm
5.000



ISO / BT 40
Kg 7
ISO / BT 50
Kg 12



ER32
Ø2/20

LÍNEA EVOLUCIÓN ATC

F90-20S

PRECIO ~~€ 3.749~~
PRECIO ESPECIAL: € 3.000

EQUIPAMIENTO ESTÁNDAR

Bolsa especial / Tope / Tuerca ER / Llaves / Tubo de grasa / Libro de instrucciones

Ve a la página del catálogo para saber más



ISO / 40
CAT / 50
BT / 50



Ratio
1:8



Rpm
24.000 output
3.000 input



Kw 8



Nm 9,5



ISO / BT 40
Kg 6
ISO / BT 50
Kg 8,5



Ø 13



ER20
Ø1/13



N 413

LÍNEA EVOLUCIÓN

GSP 13

PRECIO ~~€ 3.252~~
PRECIO ESPECIAL: € 3.000

MANGOS INTERCAMBIABLES

Conos motorizados intercambiables para adaptarse a cualquier cabezal de máquina. Un cabezal para muchas máquinas.

CABEZAL DE ACERO

Cuerpo del cabezal de acero tratado con posición de 360° y presión de aire interna, máxima rigidez y resistente a la corrosión.

AÚN MÁS RÁPIDO

Velocidad aumentada en +30% para todo el rango

REFRIGERACIÓN INTERNA

Refrigeración interna disponible en toda la gama con presión hasta 70bar